

FLASHRUNNER

High-Performance, Standalone In-System Programmer

FlashRunner Quattro Series User's Manual

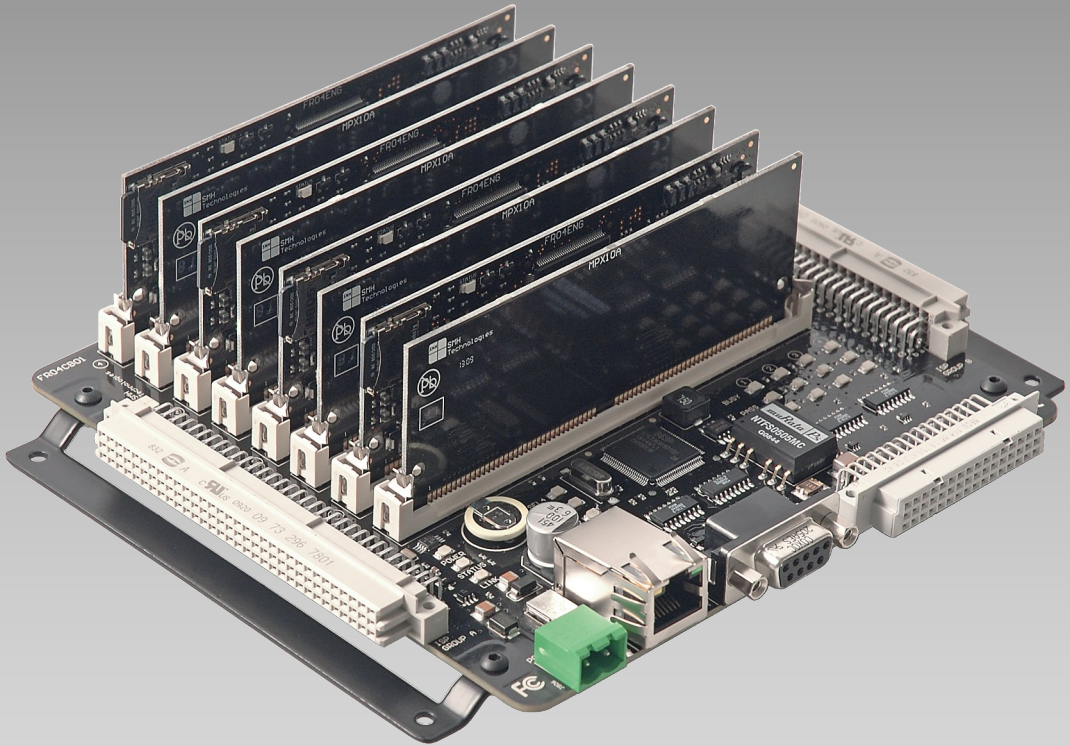

FlashRunner Quattro Series

High-Performance, Standalone Gang In-System Programmable

User's Manual

Revision 1.0 — November 2009



Copyright © 2009 SMH Technologies
DC10135

We want your feedback!

SMH Technologies is always on the lookout for new ways to improve its Products and Services. For this reason feedback, comments, suggestions or criticisms, however small, are always welcome.



Our policy at SMH Technologies is to comply with all applicable worldwide safety and EMC/EMI regulations. Our products are certified to comply with the European New Approach Directives and the CE mark is applied on all our products.

This product as shipped from the factory has been verified to meet with requirements FCC as a CLASS A product.



In a domestic environment, this product may cause radio interference in which case the user may be required to take adequate prevention measures.

Attaching additional wiring to this product or modifying the product operation from the factory default as shipped may effect its performance and cause interference with other apparatus in the immediate vicinity. If such interference is detected, suitable mitigating measures should be taken.

SMH Technologies

E-mail (general information): info@smh-tech.com

E-mail (technical support): support@smh-tech.com

Web: <http://www.smh-tech.com>

Important

SMH Technologies reserves the right to make improvements to FlashRunner, its documentation and software routines, without notice. Information in this manual is intended to be accurate and reliable. However, SMH Technologies assumes no responsibility for its use; nor for any infringements of rights of third parties which may result from its use.

SMH TECHNOLOGIES WILL NOT BE LIABLE FOR DAMAGES RESULTING FROM LOSS OF DATA, PROFITS, USE OF PRODUCTS, OR INCIDENTAL OR CONSEQUENTIAL DAMAGES, EVEN IF ADVISED OF THE POSSIBILITY THEREOF.

Trademarks

SMH Technologies is the licensee of the SofTec Microsystems trademark.

All other product or service names are the property of their respective owners.

Contents

0 Before Starting 9

- 0.1 Important Notice to Users 9
- 0.2 Safety 9
- 0.3 Getting Technical Support 10
- 0.4 Additional Documentation 10

1 Overview 11

- 1.1 What is FlashRunner Quattro? 11
 - 1.1.1 *General features* 12
 - 1.1.2 *Hardware features* 13
 - 1.1.3 *Software features* 13
- 1.2 Package Checklist 14
- 1.3 Hardware Overview 14
 - 1.3.1 *Power Supply* 14
 - 1.3.2 *LAN Connector* 14
 - 1.3.3 *LAN Reset Push-Button* 14
 - 1.3.4 *RS-232 Connector* 15
 - 1.3.5 *Control Connector* 15
 - 1.3.6 *ISP Connectors* 15
- 1.4 Programming Algorithms and Licenses 15
 - 1.4.1 *Installing New Licenses* 15
- 1.5 Upgrading the Firmware 16

2 System Setup 17

- 2.1 Overview 17
- 2.2 Software Setup 17
- 2.3 Hardware Setup 18
 - 2.3.1 *Interfacing FlashRunner with your Test/Programming Equipment* 18
 - 2.3.2 *Connecting FlashRunner to the Host PC System* 19

2.3.3 *Powering Up FlashRunner* 19

2.3.4 *Setting Up LAN Settings* 19

2.4 Step-by-Step Tutorial: Sending Commands to FlashRunner 19

3 Connectors 27

3.1 Overview 27

3.2 ISP Connectors 27

3.3 Control Connector 33

3.4 RS-232 Connector 35

4 Technical Specifications 37

4.1 Absolute Maximum Ratings 37

4.2 DC Characteristics and Functional Operating Range 37

4.3 AC Characteristics 39

4.4 Multiplexing Characteristics 40

4.5 Physical and Environmental Specifications 41

Index of Figures

- Figure 1.1: FlashRunner Quattro 11
- Figure 2.1: FlashRunner Control Panel, Communication Settings 21
- Figure 2.2: FlashRunner Control Panel, Target Device Configured 22
- Figure 2.3: FlashRunner Control Panel, Binary File Conversion 23
- Figure 2.4: FlashRunner Control Panel, File Transfer 24
- Figure 2.5: FlashRunner Control Panel, Target Device Programmed 25
- Figure 3.1: ISP GROUP Connectors 28
- Figure 3.2: Control Connector 33
- Figure 3.3: RS-232 Connector 35
- Figure 4.1: Load Conditions 40

Index of Tables

Table 3.1: ISP GROUP A Connector Signals	28
Table 3.2: ISP GROUP B Connector Signals	30
Table 3.3: Control Connector Signals	33
Table 3.4: RS-232 Connector Signals	35
Table 4.1: Absolute Maximum Ratings	37
Table 4.2: DC Characteristics and Functional Operating Range	37
Table 4.3: AC Characteristics	39
Table 4.4: Multiplexing Characteristics (FR04A08)	40
Table 4.5: Multiplexing Characteristics (FR04A16)	40
Table 4.5: Physical and Environmental Specifications	41

0 Before Starting



Note: *the FlashRunner System Software CD-ROM and/or SMH Technologies website (www.smh-tech.com) may contain an updated version of this user's manual. Please check before continuing reading this documentation.*

0.1 Important Notice to Users

While every effort has been made to ensure the accuracy of all information in this document, SMH Technologies assumes no liability to any party for any loss or damage caused by errors or omissions or by statements of any kind in this document, its updates, supplements, or special editions, whether such errors are omissions or statements resulting from negligence, accidents, or any other cause.

0.2 Safety

FlashRunner is a low-voltage device. However, when integrating it inside an automatic test equipment or when interfacing it with other systems, take all precautions in order to avoid electrical shocks due to, for example, different ground references.

Make all connections to the target system before applying power to the instrument.

To protect FlashRunner against electrostatic discharge (ESD), always connect yourself to ground (e.g. via wrist straps) when handling the instrument.

Always store FlashRunner inside an antistatic bag when not in use.

0.3 Getting Technical Support

SMH Technologies is continuously working to improve FlashRunner firmware and to release programming algorithms for new devices. SMH Technologies offers a fast and knowledgeable technical support to all of its customers and is always available to solve specific problems or meet specific needs.

To get in touch with SMH Technologies, please refer to the contact information below.

Phone: +39 0434 421111

Fax: +39 0434 639021

Technical Support: support@smh-tech.com

0.4 Additional Documentation

This user's manual provides information about how to setup FlashRunner Quattro and its hardware characteristics.

For information about FlashRunner commands and their syntax, including specific commands for specific family of microcontrollers, please refer to the FlashRunner Programmer's Manual, included (in PDF format) in the FlashRunner CD-ROM.

1 Overview

1

1.1 What is FlashRunner Quattro?

FlashRunner Quattro is a high-integration in-system gang programmer, based on the FlashRunner patented technology. FlashRunner Quattro is designed for programming multi-PCB panel assemblies, and is based on the FlashRunner technology. This means:

- Extremely fast programming (it is one of the fastest in-system programming systems on the market);
- Standalone operations (projects and code images stored on memory cards);
- Compact and robust design for production environments.

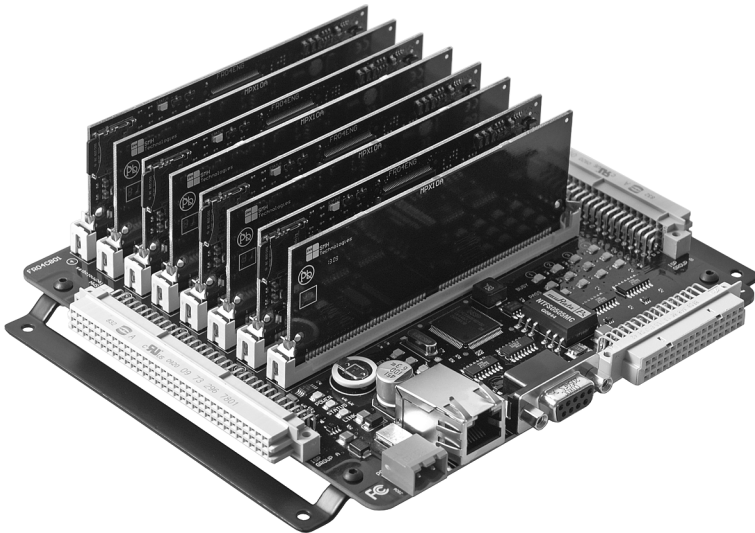

Figure 1.1: FlashRunner Quattro

1

FlashRunner Quattro is composed of a mainboard which hosts the programming and demultiplexing modules, plus various connectors used to interface to the target system and host/ATE. FlashRunner Quattro is available in three different models, to best suit different gang programming needs:

- **FR04A04:** 4 ISP channels system (4 true parallel channels), no ISP channel demultiplexing;
- **FR04A08:** 8 ISP channels system (4 parallel channels, each demultiplexable to 2 channels, with galvanic isolation);
- **FR04A16:** 16 ISP channels system (4 parallel channels, each demultiplexable to 4 channels).

In all of the above configurations, each of the ISP channels is composed of:

- Six digital, bidirectional lines;
- Two analog/digital lines (analog out, digital in/out);
- Two power lines;
- One ground line (common for all channels).

1.1.1 General features

- Fastest programming algorithms (as fast as target device's memory technology limit), approved by silicon manufacturers;
- Easy ATE integration;
- Standalone operations (projects and code images stored on memory cards);
- Controllable by ATE through optoisolated LAN, RS-232 or parallel control lines;
- Supports most ISP protocols (BDM, JTAG, SPI, I2C, MON, ICC, SCI, etc.);
- Flexible, fully configurable;
- Compact and robust design for production environments;
- Data integrity guaranteed (every data transfer to/from the host system or Secure Digital card is CRC tagged).

1.1.2 Hardware features

- 9 to 18V power supply input;
- ISP lines:
 - Six digital I/O lines;
 - Two digital I/O or analog output lines;
 - Two programmable output voltages;
 - One programmable clock output
- Secure Digital memory cards (up to 2 GB);
- 512 bytes on-board dynamic memory;
- On-board timekeeper and calendar for time-stamped log file;
- Three optoisolated command inputs (START, STOP, RELAY);
- Three optoisolated status outputs (FAIL, PASS, BUSY);
- Five project selection lines (SEL[4..0]);
- Optoisolated RS-232/Ethernet channels.

1.1.3 Software features

- Fully autonomous standalone mode thanks to its SD memory cards (FAT16);
- Controllable by any host system through a terminal utility and simple ASCII protocol;
- Up to 32 hardware-selectable projects (scripts), unlimited software-selectable projects;
- Interface Library DLL to control the instrument from within user written applications;
- Optional Data Protection System to make the contents of the binary file to be programmed to the target device not readable (and not duplicable) by non-authorized people;
- Log files;
- Erase, blank check, program, read, verify, oscillator trimming, etc.

1

1.2 Package Checklist

The FlashRunner Quattro package includes the following items:

- FlashRunner Quattro unit, including SD cards already pre-installed with the programming algorithm(s) you specified at the time of purchase;
- An Ethernet cross cable;
- A RS-232 cable;
- FlashRunner “System Software” CD-ROM, containing the FlashRunner Control Panel utility and the FlashRunner Programmer’s Manual in PDF format;
- This user’s manual;
- A registration card.

1.3 Hardware Overview

FlashRunner Quattro is composed of four, independent programming modules (each one with its one SD card) and four multiplexing modules (each one dedicated to the relative programming modules).

1.3.1 Power Supply

FlashRunner Quattro is powered through a 9-18V DC terminal block connector.

1.3.2 LAN Connector

The LAN connector is used for communication with the host PC system. Use the provided Ethernet cross cable to connect FlashRunner with your PC.

1.3.3 LAN Reset Push-Button

The “LAN RESET” resets the instruments’ IP address to its factory programmed value.

1.3.4 RS-232 Connector

Alternatively, communication with the host PC can be done with the RS-232 connector. Use the provided serial cable to connect FlashRunner with your PC.

1.3.5 Control Connector

The “CONTROL” DIN connector groups the parallel control lines that an ATE system can use to control FlashRunner, instead of communicating with the instrument through the serial or Ethernet port.

1.3.6 ISP Connectors

The “ISP GROUP A” and “ISP GROUP B” DIN connectors group the input lines from the ATE system and the ISP output lines from FlashRunner.

1.4 Programming Algorithms and Licenses

FlashRunner Quattro includes programming algorithms for several devices. In order to program a specific device, however, a specific license file for that device must be purchased.



Note: *FlashRunner Quattro comes already preinstalled with the license(s) you specified at the moment of purchase. You can purchase additional licenses at any future moment.*

Programming algorithms and license files are stored in the SD card (see the FlashRunner Programmer's Manual for more information).

1.4.1 Installing New Licenses

When you buy an additional license for a specific device, you will get:

- An algorithm file (.alg);
- A license file (.lic);
- A device-specific script example (.frs).

The .alg file contains the actual programming algorithm for the requested device (and several other devices of the same family).

The .lic file contains an unlocking code that will let you use the programming algorithm. A license file enables the use of a specific programming algorithm on a specific FlashRunner instrument (licenses are serial number specific).

The script file contains an example of script to use as a starting point for your specific programming needs (for more information on scripts, see the FlashRunner Programmer's Manual).

To install the new license, do the following (for each programming module):

1. Copy the `.alg` file into the `\ALGOS` directory of the SD card (if an `.alg` file with the same name already exists, overwrite it);
2. Copy the `.lic` file into the `\LICENSES` directory of the SD card.

To copy files on the SD card, use either a standard card reader connected to a PC or transfer the files using the FlashRunner `FSENDFILE` command (for more information on FlashRunner commands, see the FlashRunner Programmer's Manual).

Alternatively, you can use the FlashRunner Control Panel utility to install new programming algorithms and licenses. For more information on the FlashRunner Control Panel please refer to the FlashRunner Programmer's Manual.

1.5 Upgrading the Firmware

The FlashRunner firmware can be easily upgraded using the provided Control Panel utility. For more information, please refer to the FlashRunner Programmer's Manual.

2 System Setup

2.1 Overview



Note: *the example shows how to set up the system for programming a Freescale MC68HC908QY4 microcontroller. For how to connect to other target devices, please refer to the FlashRunner Programmer's Manual.*

2

This chapter will explain how to set up FlashRunner Quattro for the first time. Although FlashRunner is typically used for standalone operations (Standalone mode), the examples in this chapter will use the host system to send commands to FlashRunner (Host mode).

When moving FlashRunner to the production environment, you can take full advantage of the instrument's SD cards to make the instrument work without being controlled by the host system.

For more information about Standalone mode and Host mode, see the FlashRunner Programmer's Manual.

2.2 Software Setup

The FlashRunner system software setup installs all of the required components to your hard drive. These components include:

- The FlashRunner Control Panel utility;
- Script examples;
- Documentation in PDF format.

To install the FlashRunner system software:

- Insert the “**System Software**” CD-ROM into your computer’s CD-ROM drive;
- A startup window will automatically appear. Choose “**Install Instrument Software**” from the main menu. Follow the on-screen instructions.



Note: *to install the FlashRunner system software on Windows 2000 or Windows XP, you must log in as Administrator.*

2.3 Hardware Setup

To set up FlashRunner Quattro, you must follow the steps below, in the indicated order:

1. Interface FlashRunner with your test/programming equipment;
2. Connect FlashRunner to the host PC system;
3. Power up FlashRunner;
4. Set up LAN settings (if you use the Ethernet connection);
5. Send FlashRunner commands via the FlashRunner Control Panel utility.

2.3.1 Interfacing FlashRunner with your Test/Programming Equipment

Build one or more ISP cables to connect from the FlashRunner’s “ISP GROUP” connectors to your target board(s). Make all the required connections (power, oscillator, ISP signals) to the target microcontrollers.

Typical connections for all the device families supported by FlashRunner are shown in the FlashRunner Programmer’s Manual.

2.3.2 Connecting FlashRunner to the Host PC System

You can connect FlashRunner to the host system through either the RS-232 or LAN port. Both the serial and LAN connectors are located in the Connection layer.

FlashRunner Quattro comes with a serial cable and an Ethernet cross cable to connect directly to a host PC.

2.3.3 Powering Up FlashRunner

Power up FlashRunner by connecting the output of a power supply to the terminal block connector located in the Connection layer. FlashRunner accepts any DC voltage between 9V and 18V.

2.3.4 Setting Up LAN Settings

If you connected FlashRunner to the host PC using the Ethernet connection, you need to set up the FlashRunner IP address. For learning how to set up the FlashRunner IP address, please refer to the FlashRunner Programmer's Manual.

2.4 Step-by-Step Tutorial: Sending Commands to FlashRunner

After setting up the hardware, you are ready to send commands to the instrument. The following steps will guide you through the process of launching your first FlashRunner commands using the provided FlashRunner Control Panel utility. For detailed information about the FlashRunner Control Panel utility, see the FlashRunner Programmer's Manual.



Note: *the following steps show how to program a Freescale MC68HC908QY4 microcontroller, and the details are therefore specific for that microcontroller. However, the procedures shown are general and will allow you get a feel of how FlashRunner works.*

2

1. Launch the FlashRunner Control Panel utility. Select **Start > Programs > SofTec Microsystems > FlashRunner > Control Panel**. The Control Panel utility will open.
2. To establish a connection with FlashRunner, on the “**Communication Settings**” section, select:
 - “**FlashRunner serial version**”
(if you are connected to FlashRunner through a serial port), or
 - “**FlashRunner LAN version**”
(if you are connected to FlashRunner through an Ethernet port).

Next, specify:

- The COM port you are using and the baud rate (for the serial connection—by default, FlashRunner communicates at 115200 bps), or
- The instrument IP address (for the Ethernet connection). For learning how to set up the FlashRunner IP address, please refer to the FlashRunner Programmer’s Manual.

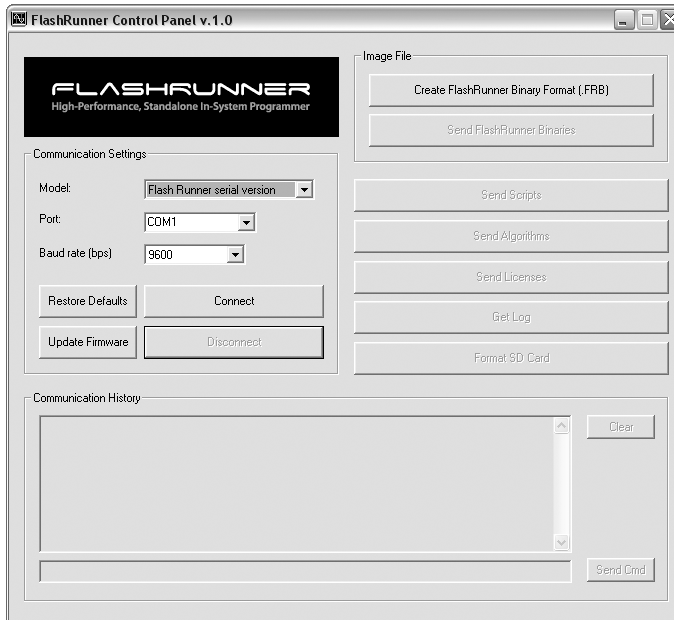

Figure 2.1: FlashRunner Control Panel, Communication Settings

3. Click the **“Connect”** button. On the **“Communication History”** section, note the commands that have been sent and received. In this case, the **MCSPING** command is automatically sent to FlashRunner, which replies with the **PONG>** string.
4. In the edit box below the communication history, type the following command (followed by Return):

MCSETENG ENG1

This commands instructs the instrument to send all subsequent commands to the first programming module.

5. Send the following additional commands:

TCSETDEV FREESCALE MC68HC908QY4 HC08
TCSETPAR FOSC 16000000

```
TCSETPAR FDIV 4
TCSETPAR VDD 5000
```

These commands set, respectively, the target microcontroller, the oscillator frequency, the internal divisor and the VDD voltage. In this example, we used a 16 MHz oscillator, the internal divisor for MC68HC908QY4 devices is fixed to 4, and the VDD is 5V. FlashRunner will respond to each command with the > string, indicating that the command has been successfully executed. After sending these commands, the Control Panel will look like the figure below.

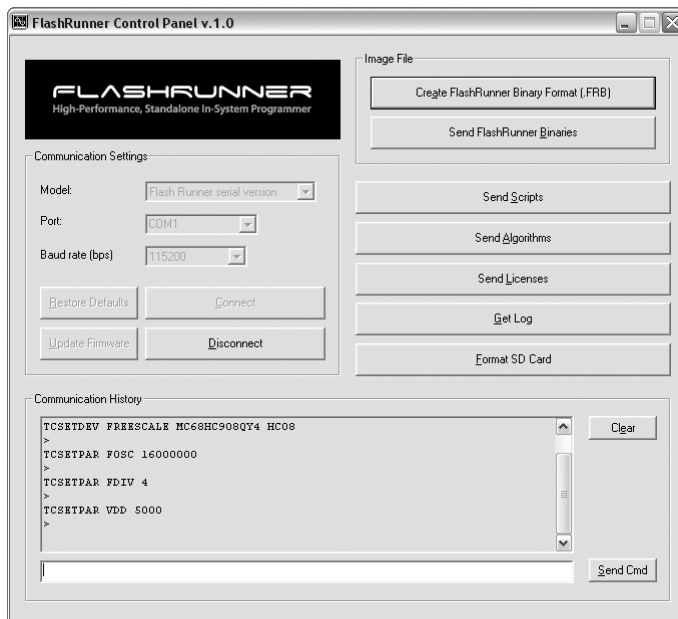

Figure 2.2: FlashRunner Control Panel, Target Device Configured

- When working with Freescale HC08 devices, FlashRunner requires you to specify the power up and power down times, in milliseconds. Send the following two commands:

```
TCSETPAR PWDOWN 10
TCSETPAR PWUP 10
```

- After specifying the target device settings, we are ready to transfer to FlashRunner the binary image to be programmed into the target device. FlashRunner accepts only image files in a .frb (FlashRunner Binary) format. To convert your binary, Intel-Hex or S19 image file to the FlashRunner format, click the “**Create FlashRunner Binary Format**” button. The following dialog box will appear.

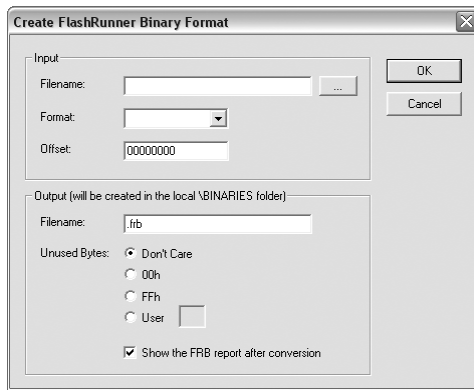

Figure 2.3: FlashRunner Control Panel, Binary File Conversion

In the “**Input**” section, specify the source file to be converted, its format, and the address from which the file conversion will start (offset). In the “**Output**” section, specify the output filename and the value used to fill unused locations.

Click the “**OK**” button. The FlashRunner Binary file will be created in the local `\BINARIES` folder.

- To transfer the created image to selected programming module, send the following command:

```
FSSENDFILE YMODEM DEMO.FRB
```

In this example, the image file is called `DEMO.FRB`. The following dialog box will appear.

2

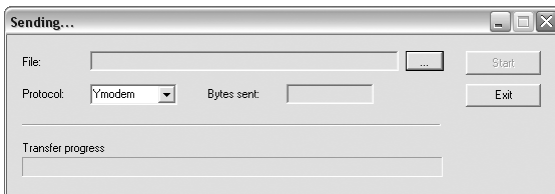

Figure 2.4: FlashRunner Control Panel, File Transfer

Click the “...” button to browse for the image file to be send, then click “**Start**” to begin the transfer. The file will be saved to the SD card of the selected programming module, in the `\BINARIES` folder.

9. **(Only for FR04A08 and FR04A16)** Next, we have to specify which of available ISP sites (for the selected programming module, in this case the first one) FlashRunner will use as output. To do this, send the following command:

```
MXCLOSE 1
```

This will select the first ISP site, routing all of the FlashRunner’s ISP lines of the first programming module to the target board through this site.

10. We are now ready to start the actual programming part. Send the following commands:

```
TPSETSRC FILE DEMO.FRB
TPSTART
TPCMD SETPWD CONST $FF $FF $FF $FF $FF $FF $FF $FF
TPCMD MASSERASE F
TPCMD BLANKCHECK F $EE00 4608
TPCMD PROGRAM F $EE00 $EE00 4608
TPCMD VERIFY F S $EE00 $EE00 4608
TPEND
```

The data to be programmed is taken from the image file starting at \$EE00 (offset from the beginning of the file), is programmed to the target microcontroller starting from the location \$EE00 and is 4608 bytes long.

The **TPSETSRC** command specifies the source file for the **TPCMD PROGRAM** e **TPCMD VERIFY** commands that come next. All the actual programming operations are sent between a **TPSTART** and **TPEND** command. The **TPCMD SETPWD** command sets the security bytes needed to perform subsequent operations.

After sending these commands, the Control Panel will look like the figure below.

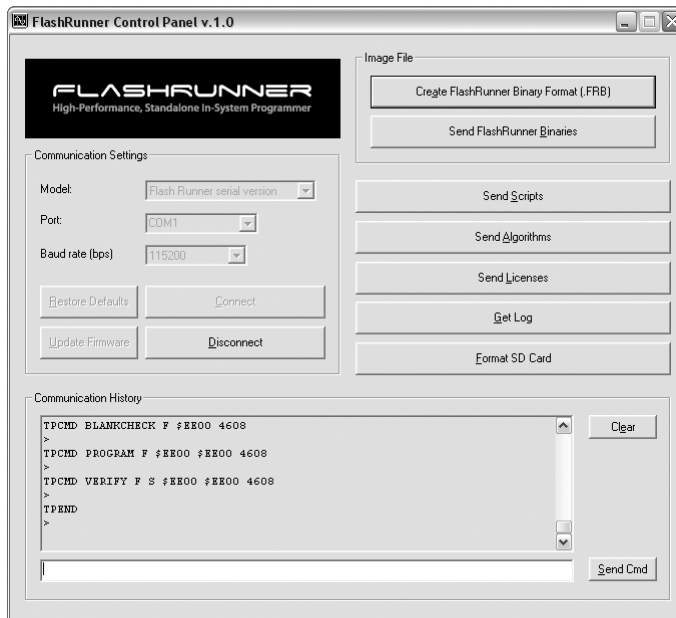

Figure 2.5: FlashRunner Control Panel, Target Device Programmed

11. We are now done with programming the target device. Click the **“Disconnect”** button to free the serial port resource.

For detailed information on all of the FlashRunner commands and their syntax, including specific commands for specific family of microcontrollers, please refer to the FlashRunner Programmer's Manual, included (in PDF format) in the FlashRunner CD-ROM.

Programming can be automated by creating "scripts". Scripts are text files, stored in the SD cards, which contain a sequence of FlashRunner commands. See the FlashRunner Programmer's Manual for more information about scripts.

2

3 Connectors

3.1 Overview

FlashRunner Quattro connects to your programming/testing system through three connectors: two connectors (“ISP GROUP A” and “ISP GROUP B”) group the outputs from FlashRunner; the other connector (“CONTROL”) groups control signals.

Additionally, an RS-232 and Ethernet connector are provided for full interfacing with the ATE system.

3

3.2 ISP Connectors

The “ISP GROUP A” and “ISP GROUP B” connectors group the signals needed to program up to 16 target devices (depending on the FlashRunner Quattro model). These connectors have several input/output lines, both digital and analog, that are automatically configured by FlashRunner depending on the specific target device to be programmed (see the FlashRunner Programmer’s Manual to learn how to connect these lines to your specific target device).



Note: *ISP and I/O signals are not optoisolated and are referenced to GND (the power supply ground).*

Additionally, in order to avoid undesired current loops between the FlashRunner power supply and the target board, a power supply with a floating output (ground not referenced to the earth potential) should be used.

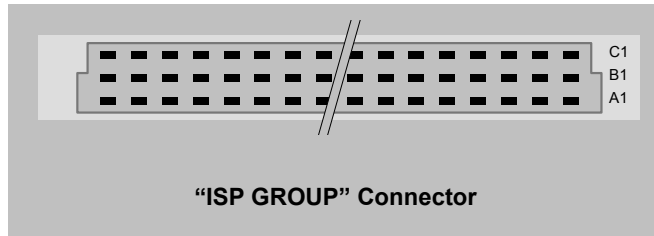

Figure 3.1: ISP GROUP Connectors

3

Table 3.1: ISP GROUP A Connector Signals

Pin #	Signal Name	Description
A1	1DIO0/AO0	ISP Site 1: Digital input/output 0 or analog output 0
A2	1DIO3	ISP Site 1: Digital input/output 3
A3	1DIO6	ISP Site 1: Digital input/output 6
A4	1VPROG0	ISP Site 1: Programmable voltage 0
A5	2DIO0/AO0	ISP Site 2: Digital input/output 0 or analog output 0
A6	2DIO3	ISP Site 2: Digital input/output 3
A7	2DIO6	ISP Site 2: Digital input/output 6
A8	2VPROG0	ISP Site 2: Programmable voltage 0
A9	3DIO0/AO0	ISP Site 3: Digital input/output 0 or analog output 0
A10	3DIO3	ISP Site 3: Digital input/output 3
A11	3DIO6	ISP Site 3: Digital input/output 6
A12	3VPROG0	ISP Site 3: Programmable voltage 0
A13	4DIO0/AO0	ISP Site 4: Digital input/output 0 or analog output 0
A14	4DIO3	ISP Site 4: Digital input/output 3
A15	4DIO6	ISP Site 4: Digital input/output 6
A16	4VPROG0	ISP Site 4: Programmable voltage 0
A17	5DIO0/AO0	ISP Site 5: Digital input/output 0 or analog output 0
A18	5DIO3	ISP Site 5: Digital input/output 3
A19	5DIO6	ISP Site 5: Digital input/output 6
A20	5VPROG0	ISP Site 5: Programmable voltage 0
A21	6DIO0/AO0	ISP Site 6: Digital input/output 0 or analog output 0
A22	6DIO3	ISP Site 6: Digital input/output 3
A23	6DIO6	ISP Site 6: Digital input/output 6
A24	6VPROG0	ISP Site 6: Programmable voltage 0
A25	7DIO0/AO0	ISP Site 7: Digital input/output 0 or analog output 0
A26	7DIO3	ISP Site 7: Digital input/output 3
A27	7DIO6	ISP Site 7: Digital input/output 6
A28	7VPROG0	ISP Site 7: Programmable voltage 0
A29	8DIO0/AO0	ISP Site 8: Digital input/output 0 or analog output 0

Pin #	Signal Name	Description
A30	8DIO3	ISP Site 8: Digital input/output 3
A31	8DIO6	ISP Site 8: Digital input/output 6
A32	8VPROG0	ISP Site 8: Programmable voltage 0
B1	1DIO1/AO1	ISP Site 1: Digital input/output 1 or analog output 1
B2	1DIO4	ISP Site 1: Digital input/output 4
B3	GND	Ground
B4	1VPROG1	ISP Site 1: Programmable voltage 1
B5	2DIO1/AO1	ISP Site 2: Digital input/output 1 or analog output 1
B6	2DIO4	ISP Site 2: Digital input/output 4
B7	GND	Ground
B8	2VPROG1	ISP Site 2: Programmable voltage 1
B9	3DIO1/AO1	ISP Site 3: Digital input/output 1 or analog output 1
B10	3DIO4	ISP Site 3: Digital input/output 4
B11	GND	Ground
B12	3VPROG1	ISP Site 3: Programmable voltage 1
B13	4DIO1/AO1	ISP Site 4: Digital input/output 1 or analog output 1
B14	4DIO4	ISP Site 4: Digital input/output 4
B15	GND	Ground
B16	4VPROG1	ISP Site 4: Programmable voltage 1
B17	5DIO1/AO1	ISP Site 5: Digital input/output 1 or analog output 1
B18	5DIO4	ISP Site 5: Digital input/output 4
B19	GND	Ground
B20	5VPROG1	ISP Site 5: Programmable voltage 1
B21	6DIO1/AO1	ISP Site 6: Digital input/output 1 or analog output 1
B22	6DIO4	ISP Site 6: Digital input/output 4
B23	GND	Ground
B24	6VPROG1	ISP Site 6: Programmable voltage 1
B25	7DIO1/AO1	ISP Site 7: Digital input/output 1 or analog output 1
B26	7DIO4	ISP Site 7: Digital input/output 4
B27	GND	Ground
B28	7VPROG1	ISP Site 7: Programmable voltage 1
B29	8DIO1/AO1	ISP Site 8: Digital input/output 1 or analog output 1
B30	8DIO4	ISP Site 8: Digital input/output 4
B31	GND	Ground
B32	8VPROG1	ISP Site 8: Programmable voltage 1
C1	1DIO2	ISP Site 1: Digital input/output 2
C2	1DIO5	ISP Site 1: Digital input/output 5
C3	1CLKOUT	ISP Site 1: Clock output
C4	GND	Ground
C5	2DIO2	ISP Site 2: Digital input/output 2
C6	2DIO5	ISP Site 2: Digital input/output 5
C7	2CLKOUT	ISP Site 2: Clock output

Connectors

3

Pin #	Signal Name	Description
C8	GND	Ground
C9	3DIO2	ISP Site 3: Digital input/output 2
C10	3DIO5	ISP Site 3: Digital input/output 5
C11	3CLKOUT	ISP Site 3: Clock output
C12	GND	Ground
C13	4DIO2	ISP Site 4: Digital input/output 2
C14	4DIO5	ISP Site 4: Digital input/output 5
C15	4CLKOUT	ISP Site 4: Clock output
C16	GND	Ground
C17	5DIO2	ISP Site 5: Digital input/output 2
C18	5DIO5	ISP Site 5: Digital input/output 5
C19	5CLKOUT	ISP Site 5: Clock output
C20	GND	Ground
C21	6DIO2	ISP Site 6: Digital input/output 2
C22	6DIO5	ISP Site 6: Digital input/output 5
C23	6CLKOUT	ISP Site 6: Clock output
C24	GND	Ground
C25	7DIO2	ISP Site 7: Digital input/output 2
C26	7DIO5	ISP Site 7: Digital input/output 5
C27	7CLKOUT	ISP Site 7: Clock output
C28	GND	Ground
C29	8DIO2	ISP Site 8: Digital input/output 2
C30	8DIO5	ISP Site 8: Digital input/output 5
C31	8CLKOUT	ISP Site 8: Clock output
C32	GND	Ground

Table 3.2: ISP GROUP B Connector Signals

Pin #	Signal Name	Description
A1	9DIO0/AO0	ISP Site 9: Digital input/output 0 or analog output 0
A2	9DIO3	ISP Site 9: Digital input/output 3
A3	9DIO6	ISP Site 9: Digital input/output 6
A4	9VPROG0	ISP Site 9: Programmable voltage 0
A5	10DIO0/AO0	ISP Site 10: Digital input/output 0 or analog output 0
A6	10DIO3	ISP Site 10: Digital input/output 3
A7	10DIO6	ISP Site 10: Digital input/output 6
A8	10VPROG0	ISP Site 10: Programmable voltage 0
A9	11DIO0/AO0	ISP Site 11: Digital input/output 0 or analog output 0
A10	11DIO3	ISP Site 11: Digital input/output 3
A11	11DIO6	ISP Site 11: Digital input/output 6
A12	11VPROG0	ISP Site 11: Programmable voltage 0

Pin #	Signal Name	Description
A13	12DIO0/AO0	ISP Site 12: Digital input/output 0 or analog output 0
A14	12DIO3	ISP Site 12: Digital input/output 3
A15	12DIO6	ISP Site 12: Digital input/output 6
A16	12VPROG0	ISP Site 12: Programmable voltage 0
A17	13DIO0/AO0	ISP Site 13: Digital input/output 0 or analog output 0
A18	13DIO3	ISP Site 13: Digital input/output 3
A19	13DIO6	ISP Site 13: Digital input/output 6
A20	13VPROG0	ISP Site 13: Programmable voltage 0
A21	14DIO0/AO0	ISP Site 14: Digital input/output 0 or analog output 0
A22	14DIO3	ISP Site 14: Digital input/output 3
A23	14DIO6	ISP Site 14: Digital input/output 6
A24	14VPROG0	ISP Site 14: Programmable voltage 0
A25	15DIO0/AO0	ISP Site 15: Digital input/output 0 or analog output 0
A26	15DIO3	ISP Site 15: Digital input/output 3
A27	15DIO6	ISP Site 15: Digital input/output 6
A28	15VPROG0	ISP Site 15: Programmable voltage 0
A29	16DIO0/AO0	ISP Site 16: Digital input/output 0 or analog output 0
A30	16DIO3	ISP Site 16: Digital input/output 3
A31	16DIO6	ISP Site 16: Digital input/output 6
A32	16VPROG0	ISP Site 16: Programmable voltage 0
B1	9DIO1/AO1	ISP Site 9: Digital input/output 1 or analog output 1
B2	9DIO4	ISP Site 9: Digital input/output 4
B3	GND	Ground
B4	9VPROG1	ISP Site 9: Programmable voltage 1
B5	10DIO1/AO1	ISP Site 10: Digital input/output 1 or analog output 1
B6	10DIO4	ISP Site 10: Digital input/output 4
B7	GND	Ground
B8	10VPROG1	ISP Site 10: Programmable voltage 1
B9	11DIO1/AO1	ISP Site 11: Digital input/output 1 or analog output 1
B10	11DIO4	ISP Site 11: Digital input/output 4
B11	GND	Ground
B12	11VPROG1	ISP Site 11: Programmable voltage 1
B13	12DIO1/AO1	ISP Site 12: Digital input/output 1 or analog output 1
B14	12DIO4	ISP Site 12: Digital input/output 4
B15	GND	Ground
B16	12VPROG1	ISP Site 12: Programmable voltage 1
B17	13DIO1/AO1	ISP Site 13: Digital input/output 1 or analog output 1
B18	13DIO4	ISP Site 13: Digital input/output 4
B19	GND	Ground
B20	13VPROG1	ISP Site 13: Programmable voltage 1
B21	14DIO1/AO1	ISP Site 14: Digital input/output 1 or analog output 1
B22	14DIO4	ISP Site 14: Digital input/output 4

Connectors

3

Pin #	Signal Name	Description
B23	GND	Ground
B24	14VPROG1	ISP Site 14: Programmable voltage 1
B25	15DIO1/AO1	ISP Site 15: Digital input/output 1 or analog output 1
B26	15DIO4	ISP Site 15: Digital input/output 4
B27	GND	Ground
B28	15VPROG1	ISP Site 15: Programmable voltage 1
B29	16DIO1/AO1	ISP Site 16: Digital input/output 1 or analog output 1
B30	16DIO4	ISP Site 16: Digital input/output 4
B31	GND	Ground
B32	16VPROG1	ISP Site 16: Programmable voltage 1
C1	9DIO2	ISP Site 9: Digital input/output 2
C2	9DIO5	ISP Site 9: Digital input/output 5
C3	9CLKOUT	ISP Site 9: Clock output
C4	GND	Ground
C5	10DIO2	ISP Site 10: Digital input/output 2
C6	10DIO5	ISP Site 10: Digital input/output 5
C7	10CLKOUT	ISP Site 10: Clock output
C8	GND	Ground
C9	11DIO2	ISP Site 11: Digital input/output 2
C10	11DIO5	ISP Site 11: Digital input/output 5
C11	11CLKOUT	ISP Site 11: Clock output
C12	GND	Ground
C13	12DIO2	ISP Site 12: Digital input/output 2
C14	12DIO5	ISP Site 12: Digital input/output 5
C15	12CLKOUT	ISP Site 12: Clock output
C16	GND	Ground
C17	13DIO2	ISP Site 13: Digital input/output 2
C18	13DIO5	ISP Site 13: Digital input/output 5
C19	13CLKOUT	ISP Site 13: Clock output
C20	GND	Ground
C21	14DIO2	ISP Site 14: Digital input/output 2
C22	14DIO5	ISP Site 14: Digital input/output 5
C23	14CLKOUT	ISP Site 14: Clock output
C24	GND	Ground
C25	15DIO2	ISP Site 15: Digital input/output 2
C26	15DIO5	ISP Site 15: Digital input/output 5
C27	15CLKOUT	ISP Site 15: Clock output
C28	GND	Ground
C29	16DIO2	ISP Site 16: Digital input/output 2
C30	16DIO5	ISP Site 16: Digital input/output 5
C31	16CLKOUT	ISP Site 16: Clock output
C32	GND	Ground

3.3 Control Connector

The “CONTROL” D-Sub connector is used to communicate with the host system and for integration with automatic programming/testing equipment.



Note: *all control signals are referenced to GND_I, separate from GND.*

This allows a host system to safely communicate with FlashRunner Quattro even when the target board has a different ground reference than the host system's (and it's not possible to connect them together).

Additionally, in order to avoid undesired current loops between the FlashRunner power supply and the target board, a power supply with a floating output (ground not referenced to the earth potential) should be used.

3

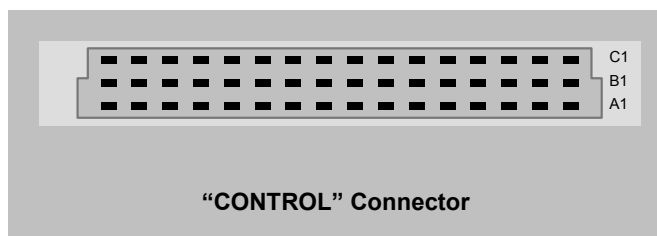

Figure 3.2: Control Connector

Table 3.3: Control Connector Signals

Pin #	Signal Name	Description
A1	SEL0	Script selection 0 (input, referenced to GND_I)
A2	SEL1	Script selection 1 (input, referenced to GND_I)
A3	SEL2	Script selection 2 (input, referenced to GND_I)
A4	SEL3	Script selection 3 (input, referenced to GND_I)
A5	SEL4	Script selection 4 (input, referenced to GND_I)
A6	SG0	ISP site selection 0 (input, referenced to GND_I)
A7	SG1	ISP site selection 1 (input, referenced to GND_I)
A8	5V_I_FUSE	5V output (output, fuse-protected, referenced to GND_I)

Connectors

3

Pin #	Signal Name	Description
A9	GND_I	Ground
A10	GND_I	Ground
A11	GND_I	Ground
A12	GND_I	Ground
A13	GND_I	Ground
A14	GND_I	Ground
A15	GND_I	Ground
A16	GND_I	Ground
B1	START1	Programming module 1 START (input , referenced to GND_I, active low)
B2	BUSY1	Programming module 1 BUSY (output, referenced to GND_I, active low)
B3	PASS1	Programming module 1 PASS (output , referenced to GND_I, active low)
B4	FAIL1	Programming module 1 FAIL (output , referenced to GND_I, active low)
B5	5V_I_FUSE	5V output (output, fuse-protected, referenced to GND_I)
B6	GND_I	Ground
B7	GND_I	Ground
B8	GND_I	Ground
B9	GND_I	Ground
B10	GND_I	Ground
B11	GND_I	Ground
B12	START2	Programming module 2 START (input , referenced to GND_I, active low)
B13	BUSY2	Programming module 2 BUSY (output, referenced to GND_I, active low)
B14	PASS2	Programming module 2 PASS (output , referenced to GND_I, active low)
B15	FAIL2	Programming module 2 FAIL (output , referenced to GND_I, active low)
B16	5V_I_FUSE	5V output (output, fuse-protected, referenced to GND_I)
C1	START3	Programming module 3 START (input , referenced to GND_I, active low)
C2	BUSY3	Programming module 3 BUSY (output, referenced to GND_I, active low)
C3	PASS3	Programming module 3 PASS (output , referenced to GND_I, active low)
C4	FAIL3	Programming module 3 FAIL (output , referenced to GND_I, active low)
C5	5V_I_FUSE	5V output (output, fuse-protected, referenced to GND_I)
C6	GND_I	Ground
C7	GND_I	Ground
C8	GND_I	Ground
C9	GND_I	Ground
C10	GND_I	Ground
C11	GND_I	Ground
C12	START4	Programming module 4 START (input , referenced to GND_I, active low)
C13	BUSY4	Programming module 4 BUSY (output, referenced to GND_I, active low)
C14	PASS4	Programming module 4 PASS (output , referenced to GND_I, active low)
C15	FAIL4	Programming module 4 FAIL (output , referenced to GND_I, active low)
C16	5V_I_FUSE	5V output (output, fuse-protected, referenced to GND_I)

3.4 RS-232 Connector

The “RS-232” D-Sub connector can be used to communicate with the ATE system.



Note: RS-232 signals are referenced to GND_I, separate from GND.

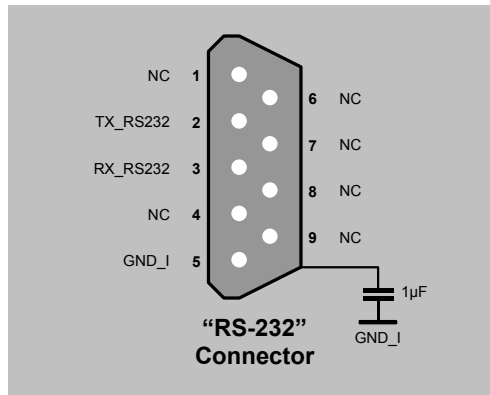

Figure 3.3: RS-232 Connector

Table 3.4: RS-232 Connector Signals

Pin #	Signal Name	Description
1	NC	Not connected
2	TX_RS232	TX (output, referenced to GND_I, RS-232 levels)
3	RX_RS232	RX (input, referenced to GND_I, RS-232 levels)
4	NC	Not connected
5	GND_I	Ground
6	NC	Not connected
7	NC	Not connected
8	NC	Not connected
9	NC	Not connected

4 Technical Specifications

4.1 Absolute Maximum Ratings

Table 4.1: Absolute Maximum Ratings

Parameter	Value
“POWER” Connector	
Maximum supply voltage on line POWER (reference GND)	-20V to +20V
“CONTROL” Connector	
Maximum input voltage on lines START, SEL[4..0], SG[1..0]	-2V to +20V
Maximum current on lines BUSY, PASS, FAIL	±10mA
“ISP GROUP” Connectors	
Maximum input voltage on lines DIO/AO[1..0], DIO[6..2], CLKOUT	-1V to +7V
Maximum current on lines DIO/AO[1..0], DIO[6..2], CLKOUT	±50mA
Maximum current on line VPROG0	500mA
Maximum current on line VPROG1	250mA
“RS-232” Connector	
Maximum input voltage on line RX_RS232	-25V to +25V
Maximum current on line TX_RS232	±60mA

4

4.2 DC Characteristics and Functional Operating Range

Table 4.2: DC Characteristics and Functional Operating Range

Parameter	Condition	Value		
		Min	Typ	Max
“CONTROL” Connector				
V_{IL} (input low voltage) on lines START, SEL[4..0]		0V	-	0.8V
V_{IH} (input high voltage) on lines START, SEL[4..0]		2.4V	-	15V
V_{OL} (output low voltage) on lines BUSY, FAIL, PASS	$I_{OL} = 4mA$	-	-	0.8V

Technical Specifications

Parameter	Condition	Value		
		Min	Typ	Max
V_{OH} (output high voltage) on lines BUSY, FAIL, PASS		4.5V	-	5V
“RS-232” Connector				
V_{IL} (input low voltage) on line RX_RS232		-	-	1.2V
V_{IH} (input high voltage) on line RX_RS232		2.4V	-	-
V_{OL} (output low voltage) on line TX_RS232	$R_{LOAD} = 3K\Omega$	-	-	-5V
V_{OH} (output high voltage) on line TX_RS232	$R_{LOAD} = 3K\Omega$	+5V	-	-
“ISP GROUP” Connectors				
V_{IL} (input low voltage) on lines DIO	Configured as digital lines	-	-	$0.3V_{PROG0}$
V_{IH} (input high voltage) on lines DIO	Configured as digital lines	$0.7V_{PROG0}$	-	V_{PROG0}
V_{OL} (output low voltage) on lines DIO, CLKOUT	Configured as digital lines, $V_{PROG0} = 3V$, $I_{OL} = 12mA$	-	-	0.36V
V_{OH} (output high voltage) on lines DIO, CLKOUT	Configured as digital lines, $V_{PROG0} = 3V$, $I_{OH} = 12mA$	2.56V	-	-
V_{OL} (output low voltage) on lines DIO, CLKOUT	Configured as digital lines, $V_{PROG0} = 5.5V$, $I_{OL} = 24mA$	-	-	0.36V
V_{OH} (output high voltage) on lines DIO, CLKOUT	Configured as digital lines, $V_{PROG0} = 5.5V$, $I_{OH} = 24mA$	4.86V	-	-
I_{OH} current (source) on lines DIO	Configured as input with active pull-ups	-	3.4mA	-
DIO/AO[1..0] voltage	Configured as analog output	0V	-	14.5V
DIO/AO[1..0] IO current (sink and source)	Configured as analog output	-	-	$\pm 40mA$
I_{OH} current (source) on lines DIO/AO[1..0]	Configured as analog lines with active pull-ups	-	5.5mA	-
VPROG0 output voltage		1.6V	-	5.5V
VPROG0 current (source)		-	-	500mA
VPROG1 output voltage		3.5V	-	13V
VPROG1 current (source)		-	-	250mA
“POWER” Connector				
Supply voltage		9V	-	18V
Power consumption		-	-	3.5A

4.3 AC Characteristics

Table 4.3: AC Characteristics

Parameter	Condition	Value			
		Min	Typ	Max	
t_{RISE} on lines DIO[6..2], DIO[1..0], CLKOUT when configured as digital output push-pull	$V_{PROG0} = 1.8V$	Load: 470 Ω //100pF (see figure 4.1a)	-	40ns	-
	$V_{PROG0} = 3.3V$		-	30ns	-
	$V_{PROG0} = 5V$		-	25ns	-
t_{FALL} on lines DIO[6..2], DIO[1..0], CLKOUT when configured as digital output push-pull	$V_{PROG0} = 1.8V$	Load: 470 Ω //100pF (see figure 4.1a)	-	35ns	-
	$V_{PROG0} = 3.3V$		-	25ns	-
	$V_{PROG0} = 5V$		-	25ns	-
t_{RISE} on lines DIO/AO[1..0] configured as analog output	$V_{PROG1} = 3V$	Load: 4.7K Ω //100pF (see figure 4.1a)	-	7 μ s	-
	$V_{PROG1} = 12V$		-	11 μ s	-
	$V_{PROG1} = 14.5V$		-	12 μ s	-
t_{FALL} on lines DIO/AO[1..0] configured as analog output	$V_{PROG1} = 3V$	Load: 100pF (see figure 4.1b)	-	8 μ s	-
	$V_{PROG1} = 12V$		-	20 μ s	-
	$V_{PROG1} = 14.5V$		-	30 μ s	-
t_{RISE} on line VPROG0	$V_{PROG0} = 0-1.8V$	Load: 15 Ω //10mF (see figure 4.1a)	-	10ms	-
	$V_{PROG0} = 0-3.3V$	Load: 22 Ω //10mF (see figure 4.1a)	-	15ms	-
	$V_{PROG0} = 0-5.5V$	Load: 22 Ω //10mF (see figure 4.1a)	-	20ms	-
t_{FALL} on line VPROG0	$V_{PROG0} = 1.8-0V$	Load: 10mF (see figure 4.1b)	-	300ms	-
	$V_{PROG0} = 3.3-0V$		-	350ms	-
	$V_{PROG0} = 5.5-0V$		-	350ms	-
t_{RISE} on line VPROG1	$V_{PROG1} = 0-3V$	Load: 10 Ω //1mF (see figure 4.1a)	-	1.3ms	-
	$V_{PROG1} = 0-5V$	Load: 47 Ω //1mF (see figure 4.1a)	-	1.8ms	-
	$V_{PROG1} = 0-14.5V$	Load: 94 Ω //1mF (see figure 4.1a)	-	13ms	-
t_{FALL} on line VPROG1	$V_{PROG1} = 3-0V$	Load: 1mF (see figure 4.1b)	-	18ms	-
	$V_{PROG1} = 5-0V$		-	30ms	-
	$V_{PROG1} = 14.5-0V$		-	45ms	-
CLKOUT frequency			0MHz	-	50MHz

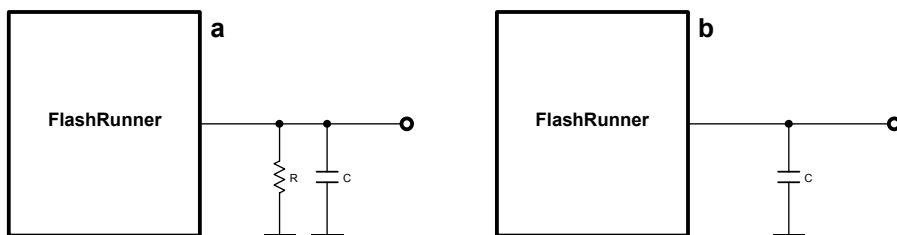

Figure 4.1: Load Conditions

4.4 Multiplexing Characteristics

Table 4.4: Multiplexing Characteristics (FR04A08)

Parameter	Value
Switch type on lines DIO/AO[1..0], DIO[6..2], CLKOUT	Reed Relay
Switch type on lines VPROG[1..0]	Reed Relay
Off resistance on lines DIO/AO[1..0]	$10^{12}\Omega$ Typ
Off resistance on lines DIO[6..2], CLKOUT	$10^{12}\Omega$ Typ
Off resistance on lines VPROG[1..0]	$10^{12}\Omega$ Typ
On resistance on lines DIO/AO[1..0]	100m Ω Max
On resistance on lines DIO[6..2], CLKOUT	100m Ω Max
On resistance on lines VPROG[1..0]	100m Ω Max
Open time	20 μ s Max
Close time	100 μ s Max
Relay life	100m Ω Max

Table 4.5: Multiplexing Characteristics FR04A16)

Parameter	Value
Switch type on lines DIO/AO[1..0], DIO[6..2], CLKOUT	CMOS
Switch type on lines VPROG[1..0]	Reed Relay
Off resistance on lines DIO/AO[1..0]	$2^9\Omega$ Typ
Off resistance on lines DIO[6..2], CLKOUT	$15^9\Omega$ Typ
Off resistance on lines VPROG[1..0]	$10^{12}\Omega$ Typ
On resistance on lines DIO/AO[1..0]	4 Ω Typ
On resistance on lines DIO[6..2], CLKOUT	2.5 Ω Typ
On resistance on lines VPROG[1..0]	100m Ω Max
Bandwidth on lines DIO/AO[1..0]	120MHz Typ
Bandwidth on lines DIO[6..2], CLKOUT	200MHz Typ

Open time	20 μ s Max
Close time	100 μ s Max
Relay life on lines DIO/AO[1..0], DIO[6..2], CLKOUT	Unlimited
Relay life on lines VPROG[1..0]	100MCycles Typ

4.5 Physical and Environmental Specifications

Table 4.6: Physical and Environmental Specifications

Parameter	Value
Dimensions, without mounting brackets	165 x 155 x 50 mm
Dimensions, without mounting brackets	180 x 155 x 55 mm
"ISP GROUP" connectors type	96 way, 3 row, DIN 41612, reverse, pitch = 2.54mm (female)
"CONTROL" connector type	48 way, 3 row, DIN 41612, reverse, pitch = 2.54mm (female)
"RS-232" connector type	9-pin, 2.54mm-pitch, D-Sub (female)
"LAN" connector type	RJ-45 connector
"POWER" connector type	Terminal block connector, pitch = 5.08mm
Operating temperature	0-50°C
Operating humidity	90% max (without condensation)
Storage temperature	0-70°C
Storage humidity	90% max (without condensation)

SMH Technologies S.r.l.
via Giovanni Agnelli, 1
33083 Villotta di Chions (PN) Italy

SMH Technologies is the licensee of the SofTec Microsystems trademark